

# AL3PA

NEW OPTION  
DOUBLE-RAIL WIDTH  
1060 & 850 mm

NEW  
2022

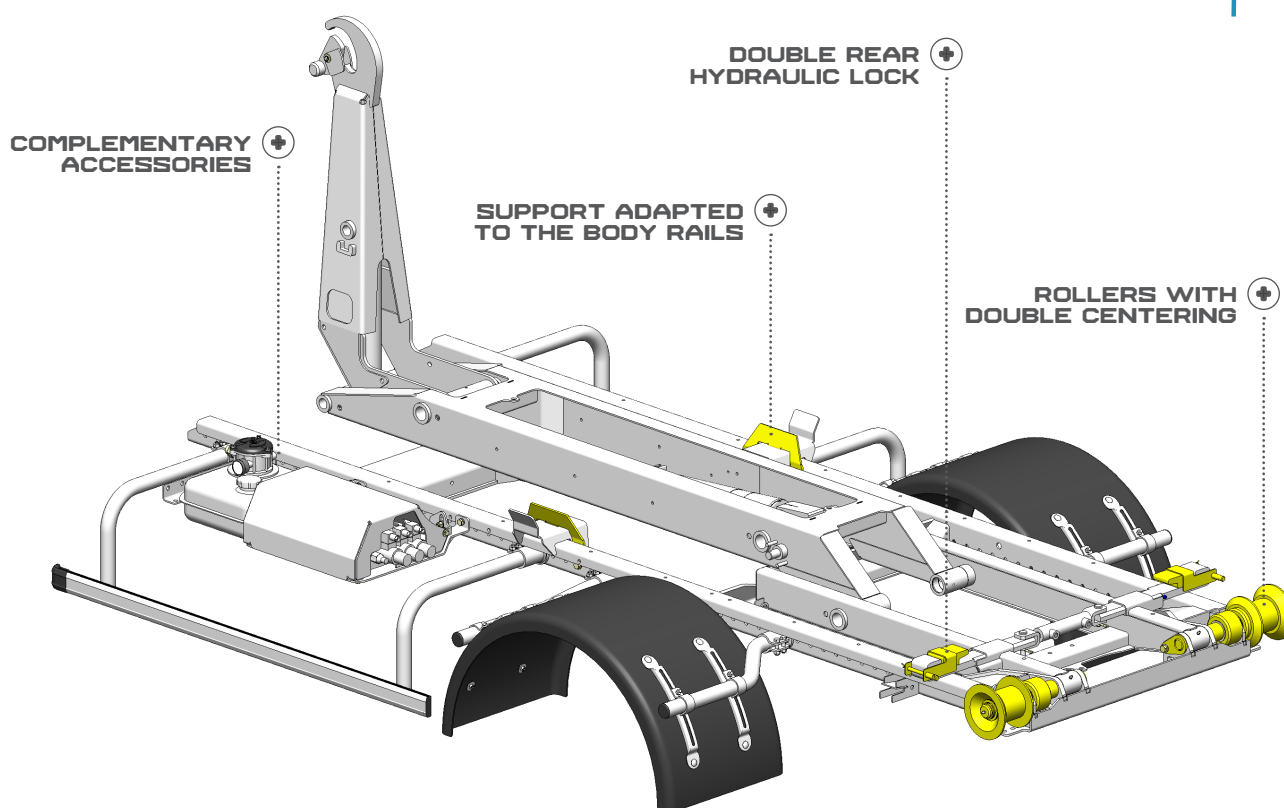

## HIGH-LIGHTS

- > **COMPLETE KIT:**  
time saving for installation
- > **DOUBLE REAR** hydraulic lock:  
storing of the lock wedges
- > **OPTIMIZED POSITION** of the hydraulic box
- > **NEW ACCESSORIES:**  
**SET OF FENDERS** with supports
- > **NEW ACCESSORIES:**  
**SET OF SIDE PROTECTIONS**
- > **FRAME EXTENSION FOR BOX** behind the cab (additional option)

# AL3PA

NEW OPTION  
DOUBLE-RAIL WIDTH  
1060 & 850 mm



## OPTIONS & ACCESSORIES

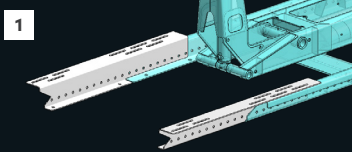

1  
Frame extension for box behind the cab

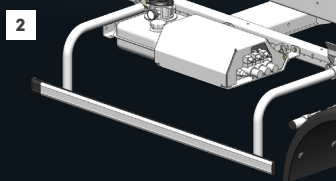

2  
Set of side protections

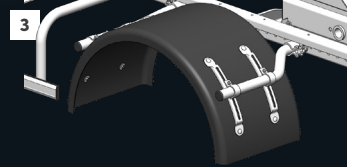

3  
Set of fenders with supports

Other options available for custom configuration

FICHEPRODUIT/AL3PA-DOUBLE-PISTE/032022/0EN - ohlstudio (r)

## TECHNICAL DATA

For GVW up to 5.5 T		A26	A28	A30
	Container length (mm)	2 800	3 000	3 200
	Tipping angle (°)	50	50	50
	Loading angle* (°)	30	30	30
	Weight (kg)	370	380	380

Subject to technical modification; data not binding

\* Chassis height 800 mm

# AMPLIROLL® URBAN

+33 (0)4 77 36 28 28  
42 avenue de Saint-Étienne – BP70056  
42161 Andrézieux-Bouthéon cedex  
FRANCE

@marrelsas

**MARREL**  
FASSI GROUP

MARREL.com