

AMPLIROLL® HIGH

LP

RANGE



POWERFUL ■ CONVENIENT

ROBUST ■ VERSATILE

 **MARREL**
FOREVER HIGHER SINCE 1919

A FASSI GROUP COMPANY

LOW PROFILE HOOKLIFT

> A complete range with a height of 195 mm <

POWERFUL

Performance

- **Free tilting frame** guaranteeing unmatched lifting capacity
- **Booster system** to assist the main cylinder

Efficiency

- **Maximum productivity** thanks to the higher available space
- **Stability** in all situations

LP
RANGE

CONVENIENT

Ease of use

- **Sliding pads** between jib and main arm
- **Free glide** for a smooth translation [OPTION]

Ampli'Drive Controls

[STANDARD]

- **Electric Fit Drive** (cabin control) with a dynamic screen and a compact design

[OPTION]

- **Remote Fit Drive**



ROBUST

Product Quality Chart

- High quality **strength steels**
- **24.000** endurance tests

Manufacturing Process

- **100% integrated** in our premises
- **Qualified** painting process



UTAC CERAM

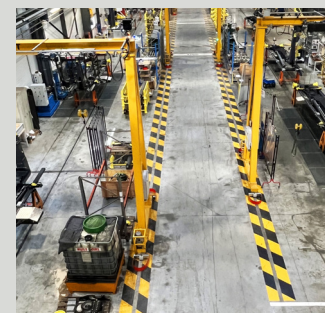

VERSATILE

The widest range on the market

- Equipments from **18T** to **24T**
- **Lengths from 49** to **61** available

All equipments are available with a telescopic or an articulated jib

LOW PROFILE HOOKLIFT

OPTIONS AND ACCESSORIES



Hooks selection
Heights & types



Rear Hydraulic Locking

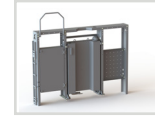

Front Hydraulic Boxes & Oiltank



Ampli'Drive Controls

- Fast speed
- Sequence control



Free Glide

- Frictionless drive

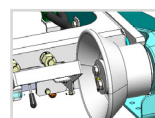

Hydraulic by-pass



Rear Underrun Protection

- Fixed
- Telescopic
- Panto
- Inclined

Additional options & accessories available for customized configuration

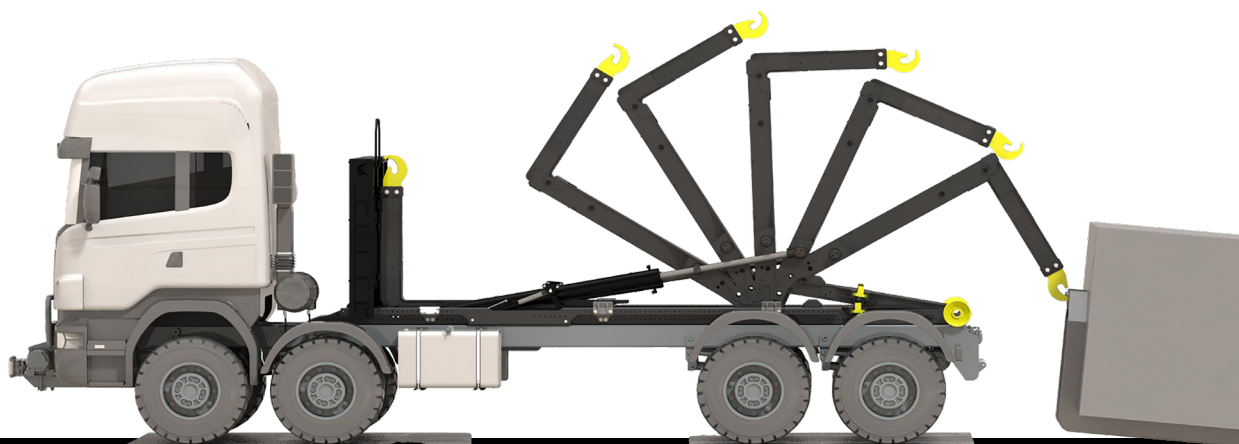

MARREL
FOREVER HIGHER SINCE 1919

+33 (0)4 77 36 28 28
42 avenue de Saint-Étienne - BP 70056
42161 Andrézieux-Bouthéon cedex
FRANCE

MARREL.COM

A FASSI GROUP COMPANY